

Universal Charge & Sync Cabinet for Tablets/iPads® - 10 Slot Charging Station with Lock and Fan

ST10CSU2A

*** This page is an addendum to the warning label found on the product.**

The Warning Label (250V/5A) is required to satisfy a Regulatory Requirement for maximum input power source availability, due to the internal, replaceable, protection fuse implementation. This version of product has been configured to accommodate a standard North American 60Hz; 115V AC, 15A power source line cord.

DE: Bedienungsanleitung - de.startech.com

FR: Guide de l'utilisateur - fr.startech.com

ES: Guía del usuario - es.startech.com

IT: Guida per l'uso - it.startech.com

NL: Gebruiksaanwijzing - nl.startech.com

PT: Guia do usuário - pt.startech.com

For the most up-to-date information, please visit: www.startech.com

Universal Charge & Sync Cabinet for Tablets/iPads® - 10 Slot Charging Station with Lock and Fan

ST10CSU2A



*actual product may vary from photos

DE: Bedienungsanleitung - de.startech.com

FR: Guide de l'utilisateur - fr.startech.com

ES: Guía del usuario - es.startech.com

IT: Guida per l'uso - it.startech.com

NL: Gebruiksaanwijzing - nl.startech.com

PT: Guia do usuário - pt.startech.com

For the most up-to-date information, please visit: www.startech.com

FCC Compliance Statement

This equipment has been tested and found to comply with the limits for a Class B digital device, pursuant to part 15 of the FCC Rules. These limits are designed to provide reasonable protection against harmful interference in a residential installation. This equipment generates, uses and can radiate radio frequency energy and, if not installed and used in accordance with the instructions, may cause harmful interference to radio communications. However, there is no guarantee that interference will not occur in a particular installation. If this equipment does cause harmful interference to radio or television reception, which can be determined by turning the equipment off and on, the user is encouraged to try to correct the interference by one or more of the following measures:

- Reorient or relocate the receiving antenna.
- Increase the separation between the equipment and receiver.
- Connect the equipment into an outlet on a circuit different from that to which the receiver is connected.
- Consult the dealer or an experienced radio/TV technician for help

This device complies with part 15 of the FCC Rules. Operation is subject to the following two conditions: (1) This device may not cause harmful interference, and (2) this device must accept any interference received, including interference that may cause undesired operation.

Changes or modifications not expressly approved by StarTech.com could void the user's authority to operate the equipment.

Industry Canada Statement

This Class B digital apparatus complies with Canadian ICES-003.

Cet appareil numérique de la classe [B] est conforme à la norme NMB-003 du Canada.

CAN ICES-3 (B)/NMB-3(B)

Use of Trademarks, Registered Trademarks, and other Protected Names and Symbols

This manual may make reference to trademarks, registered trademarks, and other protected names and/or symbols of third-party companies not related in any way to StarTech.com. Where they occur these references are for illustrative purposes only and do not represent an endorsement of a product or service by StarTech.com, or an endorsement of the product(s) to which this manual applies by the third-party company in question. Regardless of any direct acknowledgement elsewhere in the body of this document, StarTech.com hereby acknowledges that all trademarks, registered trademarks, service marks, and other protected names and/or symbols contained in this manual and related documents are the property of their respective holders.

Table of Contents

Introduction	1
Packaging Contents	1
System Requirements.....	1
Product Diagram	2
Front View	2
Rear View.....	2
LED Indicators.....	3
Charge / Sync Toggle Button	3
Installation	3
Operation	5
Charge Mode	5
Sync Mode.....	5
Security and Surface-Mounting	5
Security Bracket.....	5
Surface-Mounting Method 1:.....	5
Surface-Mounting Method 2:.....	6
Stacking Multiple Units	6
Specifications	8
Technical Support	9
Warranty Information	9

Introduction

Packaging Contents

- 1x Charge & Sync Cabinet
- 1x USB A – B Cable (4ft)
- 2x Keys
- 1x Desk Mount Bracket (w/ Screws)
- 4x Stacking Screws
- 1x Power Cord - North American (6ft)
- 1x Instruction Manual

System Requirements

- Available AC electrical outlet
- USB-enabled host computer (for syncing purposes)
- USB cable for each tablet device connected

Product Diagram

Front View

1. Charge and Sync Toggle Button
2. USB A Ports
3. LED Status Lights x10
4. Slots for Tablets x10
5. Adjustable Trays with Cable Management grooves
6. Slide-In Door

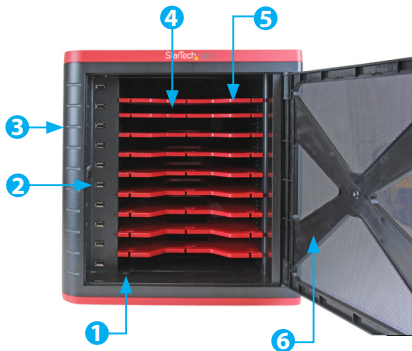

Rear View

1. Power Connector
2. Power Switch
3. USB B Host Port
4. Fan
5. Slide-Out Bracket for Cable Locks
6. Slide-Out Bracket for Surface Mounting (Lock Mechanism for separate Desk-Mount Bracket)

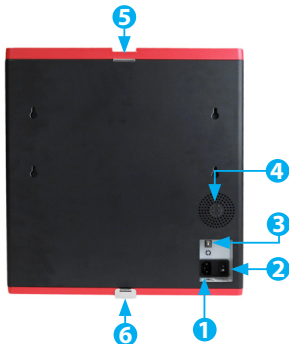

LED Indicators

LED Status	Indication
Off	No device is connected to the corresponding USB port
Red	Connected device is charging
Green	Connected device is charged - charging complete
Green and Red Flashing	Connected device is in sync mode – sync in process with host computer

Charge / Sync Toggle Button



Charge Mode - Button is in the “up” position (sync disabled)



Sync Mode - Button is in the “down” position

Installation

1. For each tablet to be connected to the ST10CSU2A, first connect your tablet device(s) directly to your host computer to ensure the computer detects and installs the device drivers to your host operating system.
2. Place the ST10CSU2A on a flat surface, and ensure the Power Switch is set to the “Off” position.
3. Connect the provided Power Cord into the power connector on the rear of the ST10CSU2A, then connect the Power Cord the to an available AC electrical outlet.
4. Connect your tablet device USB cable(s) (eg: Micro USB cable, Lightning cable, 30-Pin dock connector, etc.) into the USB Ports on the ST10CSU2A as desired.
5. Insert your tablet devices into the slots on the ST10CSU2A, and then connect the tablets connector to the USB cables from step #4. The provided trays have grooves for cable management, and can be adjusted to different heights as desired.

Note: The 9 provided adjustable trays can positioned at different heights depending on the size/thickness of your connected tablets. Adjust the trays to the desired height prior to inserting your tablet devices into the ST10CSU2A.

6. Connect the provided USB A – B Cable from the USB Host Port on the rear of the ST10CSU2A, to a USB A Port on your host computer (for sync capabilities).
7. Switch the Power Switch on the rear of the unit to the "On" position.

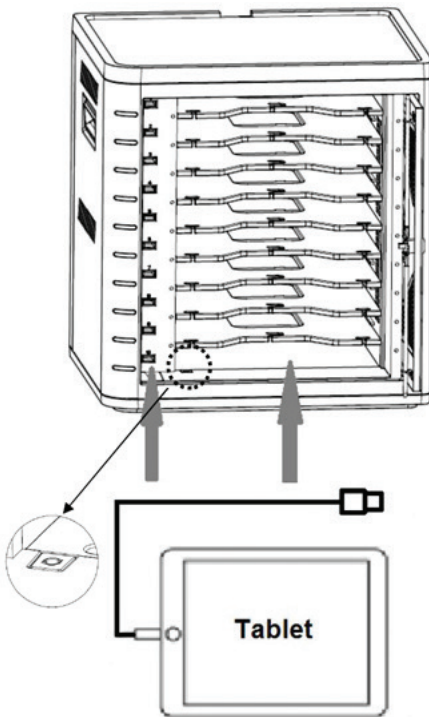

Operation

After following the previous Installation instructions, the ST10CSU2A can be used in “Charge” or “Sync” operating modes.

Charge Mode

Connected tablet devices will charge. Sync capabilities are disabled and you cannot sync your tablet device with your host computer.

1. Toggle/push the Charge and Sync Button inside the ST10CSU2A, ensure the button is in the “up” position to enable charge mode (sync is then disabled).

Sync Mode

Connected tablet devices will sync with your host computer.

1. Toggle/push the Charge and Sync Button inside the ST10CSU2A, ensure the button is in the “down” position to enable sync mode.

Note: Most devices will still provide some level of charge capabilities to your connected tablet devices while in sync mode, however, some devices cannot simultaneously charge and sync. It is recommended you switch back to charge mode once your syncing tasks are completed to continue to provide charge capabilities to your connected devices.

Security and Surface-Mounting

Follow the below procedures for attaching a security cable, or for securing the ST10CSU2A to a surface.

Note: Do not attempt to secure or mount the ST10CSU2A while your tablet devices are connected or stored inside. Ensure the Power Switch is set to the “Off” position and remove the Power Cord from the ST10CSU2A.

Security Bracket

The ST10CSU2A features a slide-out Security Bracket on the rear upper-center position of the unit. This bracket can be used with cable locks to secure the ST10CSU2A as desired.

Surface-Mounting Method 1:

The ST10CSU2A features a slide-out Surface Mounting bracket on the rear lower-center position of the unit. This bracket can be used with the provided screws to secure the ST10CSU2A to a desk surface. Pull the bracket outward, insert the screws, and secure the unit to a desk surface as desired.

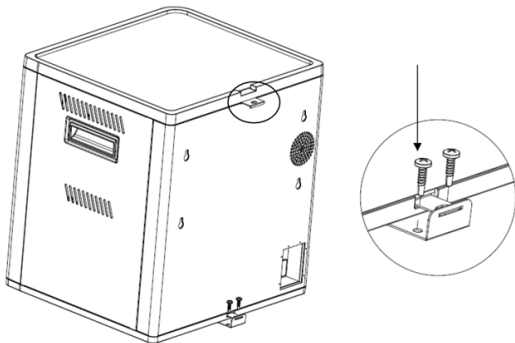

Surface-Mounting Method 2:

The ST10CSU2A also includes a separate Desk Mount Bracket.

1. Secure the Desk Mount Bracket to a surface as desired using the included screws.
2. Align the bottom of the ST10CSU2A over the secured bracket, and gently slide the bracket into the indent on the bottom of the ST10CSU2A.
3. Once in position, the integrated bracket on the rear-lower center position of the ST10CSU2A (Mentioned in Method 1) can be pushed inward, locking the Desk Mount Bracket firmly into place with the ST10CSU2A.
4. Attach a lock to the integrated bracket by looping it through the hole. This prevents the bracket from sliding backward, ensuring the bottom Desk Mount Bracket remains in a locked position and attached to the ST10CSU2A.
5. For easy removal, disconnect your lock, pull the integrated bracket outward, and the Desk Mount Bracket will become dislodged from the bottom of the ST10CSU2A.

Stacking Multiple Units

The ST10CSU2A includes 4x Stacking Screws, which allow you to horizontally or vertically stack multiple units together.

Note: Do not attempt to stack the ST10CSU2A while your tablet devices are connected or stored inside. Ensure the Power Switch is set to the "Off" position and remove the Power Cord from the ST10CSU2A.

1. Gently lift and remove the gray protective layer on the top surface of the

ST10CSU2A.

2. Align the 2x ST10CSU2A units either horizontally or vertically, top to bottom.
3. Align the 4 pilot holes on the top and bottom of the 2x ST10CSU2A.
4. Insert the 4 provided Stacking Screws through the bottom of one ST10CSU2A, and using a screwdriver, firmly secure the screws to the top of the 2nd ST10CSU2A.

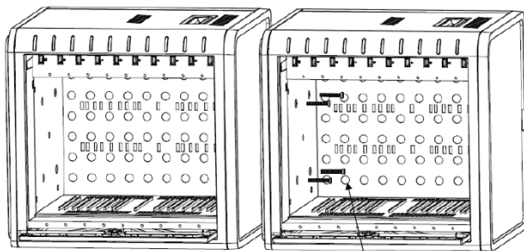
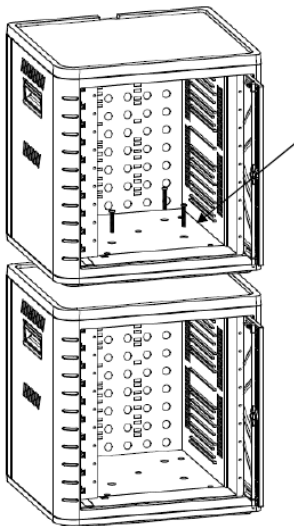

Specifications

Compatibility	USB Battery Charging Specification Rev. 1.2
Storage Capacity	10/8/6 tablet devices (adjustable trays) - Apple® iPad® or other tablets
Dimensions (W x D x H)	400mm x 350mm x 430mm
Weight	Net Weight: 15.6 kg
LED Indicators	10
Voltage	Input: 110/220V, 50/60Hz Output: DC 5V, 2.3A for each USB port

Technical Support

StarTech.com's lifetime technical support is an integral part of our commitment to provide industry-leading solutions. If you ever need help with your product, visit www.startech.com/support and access our comprehensive selection of online tools, documentation, and downloads.

For the latest drivers/software, please visit www.startech.com/downloads

Warranty Information

This product is backed by a two year warranty.

In addition, StarTech.com warrants its products against defects in materials and workmanship for the periods noted, following the initial date of purchase. During this period, the products may be returned for repair, or replacement with equivalent products at our discretion. The warranty covers parts and labor costs only. StarTech.com does not warrant its products from defects or damages arising from misuse, abuse, alteration, or normal wear and tear.

Limitation of Liability

In no event shall the liability of StarTech.com Ltd. and StarTech.com USA LLP (or their officers, directors, employees or agents) for any damages (whether direct or indirect, special, punitive, incidental, consequential, or otherwise), loss of profits, loss of business, or any pecuniary loss, arising out of or related to the use of the product exceed the actual price paid for the product. Some states do not allow the exclusion or limitation of incidental or consequential damages. If such laws apply, the limitations or exclusions contained in this statement may not apply to you.

Hard-to-find made easy. At StarTech.com, that isn't a slogan. It's a promise.

StarTech.com is your one-stop source for every connectivity part you need. From the latest technology to legacy products — and all the parts that bridge the old and new — we can help you find the parts that connect your solutions.

We make it easy to locate the parts, and we quickly deliver them wherever they need to go. Just talk to one of our tech advisors or visit our website. You'll be connected to the products you need in no time.

Visit www.startech.com for complete information on all StarTech.com products and to access exclusive resources and time-saving tools.

StarTech.com is an ISO 9001 Registered manufacturer of connectivity and technology parts. StarTech.com was founded in 1985 and has operations in the United States, Canada, the United Kingdom and Taiwan servicing a worldwide market.