

PIN ASSIGNMENT

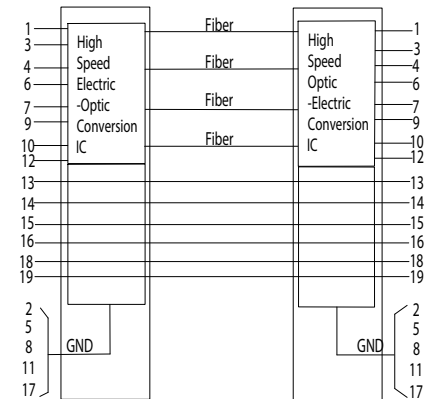

PART NUMBER	LENGTH (mm)
8K-A-30F-HDMI-CABLE	9150 ⁺¹⁰⁰ ₀
8K-A-50F-HDMI-CABLE	15250 ⁺¹⁰⁰ ₀
8K-A-100F-HDMI-CABLE	30500 ⁺¹⁰⁰ ₀

⑩	Screw
⑨	Clip
⑧	Strain Relief Black
⑦	HDMI A male shell(Bottom) Black (Display)
⑥	HDMI A male shell(Bottom) Black (Source)
⑤	HDMI A male shell(Upper) Black
④	HDMI A PCBA (Display) ATLX-HR21
③	HDMI A PCBA (Source) ATLX-HT21
②	HDMI A male Plug Gold-Plated
①	(FIBER*4C+MID)*1C+(19/0.06TC+Kevlar*2C+D+AL)*1C+[(19/0.06TC+Kevlar)*1C+7/0.12TC*1C+D+AL]+7/0.12TC*1C+7/0.16TC*1C+7/0.20TC*1C+F+AL CMP OD:4.6MM BLACK
NO.	DESCRIPTION

Tolerance Standards (mm)		THIRD ANGLE PROJECTION
Metal	Plastic	
0.5-3.0/±0.05	0.5-3.0/±0.1	 GENERAL NOTES DIMENSIONS ARE IN MM - DO NOT SCALE THIS DOCUMENT CONTAINS CONFIDENTIAL, PROPRIETARY INFORMATION THAT IS PROPERTY OF STARTECH.COM
3.0-6.0/±0.05	3.0-6.0/±0.1	
6.0-30.0/±0.05	6.0-30.0/±0.2	
≥30/±0.05	≥30/±0.3	

StarTech.com			
PRODUCT ID	8K-A-xxF-HDMI-CABLE		
DESCRIPTION	HDMI 2.1 Hybrid Active Optical Cable (AOC), CMP, Plenum Rated		
DO NOT SCALE	SHEET: 1 OF: 1	UPLOAD DATE: 3/25/2025	