

8 7 6 5 4 3 2 1

F
E
D
C
B
A

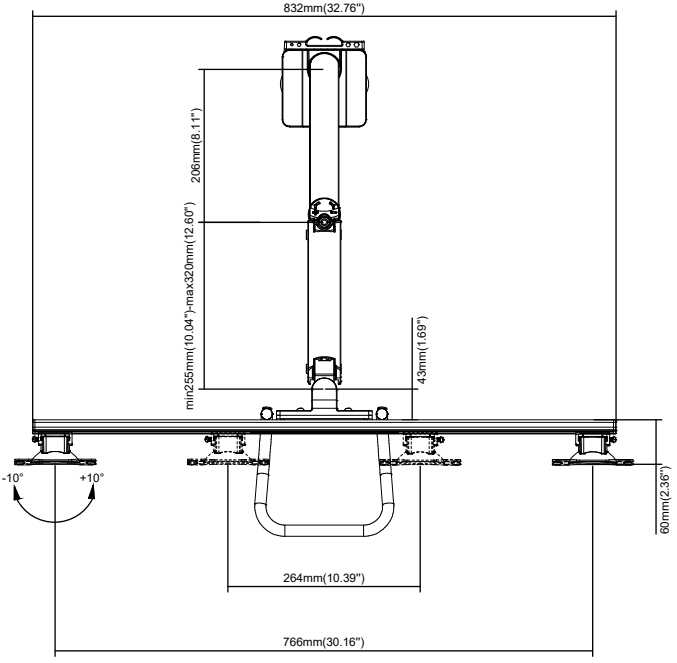

THIRD ANGLE PROJECTION

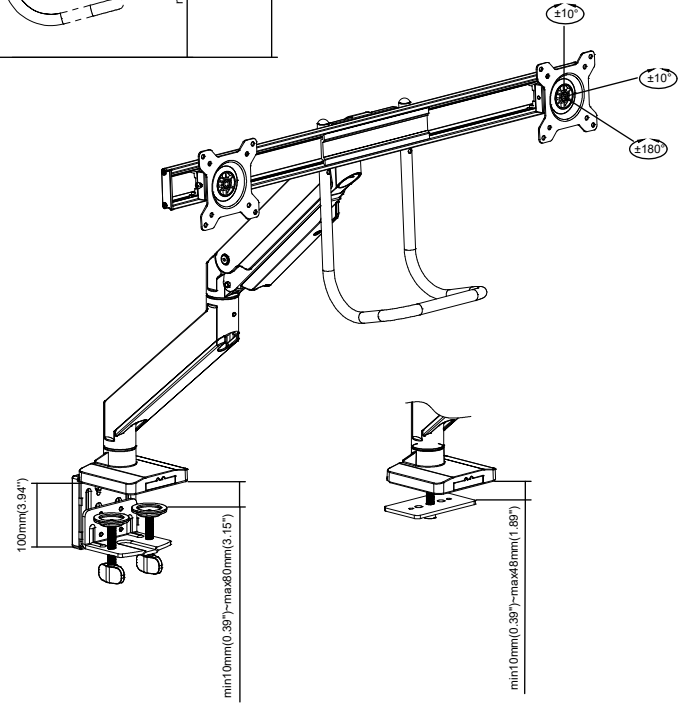
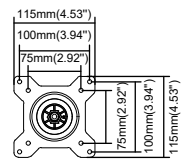
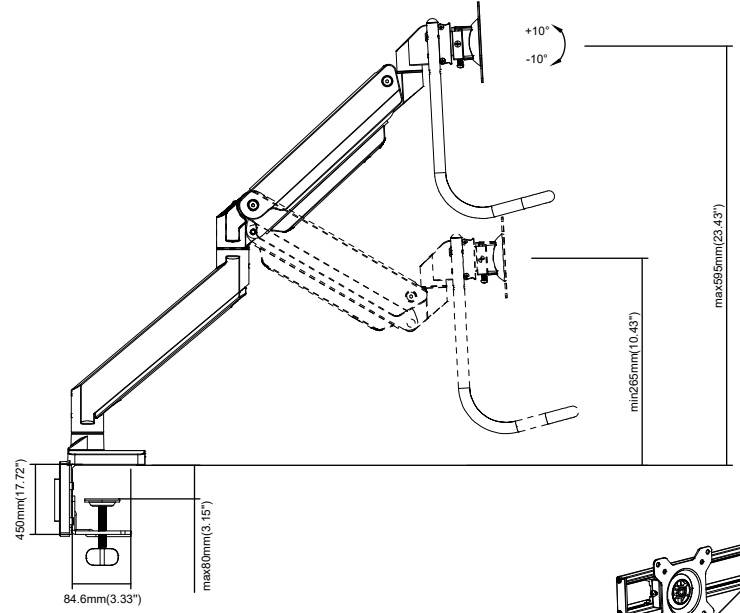
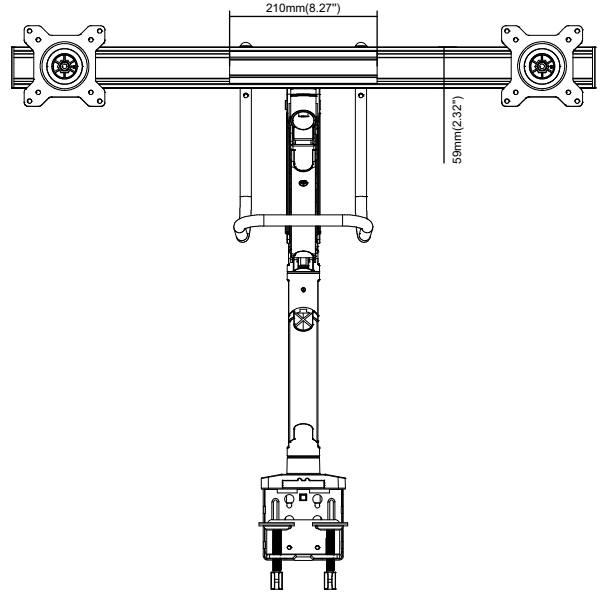
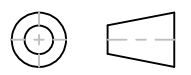

GENERAL NOTES

DIMENSIONS ARE IN MM - DO NOT SCALE
THIS DOCUMENT CONTAINS CONFIDENTIAL, PROPRIETARY INFORMATION THAT IS PROPERTY OF STARTECH.COM

StarTech.com

PRODUCT ID	ARMSLMBARDUO
DESCRIPTION	Desk Mount Dual Monitor Arm - Ergonomic Dual Monitor VESA Mount 32" (17.6lb) Displays Crossbar Handle for Synchronized Full Motion - Height Adjustable - C-Clamp/Grommet
DO NOT SCALE	SHEET: 1 OF: 1
UPLOAD DATE: 12/22/2022	

8 7 6 5 4 3 2 1