

VGA Video Extender over Cat 5 Remote Receiver (UTPE Series)

STUTPRXL / STUTPRXLGB / STUTPRXLEU

DE: Bedienungsanleitung - de.startech.com

FR: Guide de l'utilisateur - fr.startech.com

ES: Guía del usuario - es.startech.com

IT: Guida per l'uso - it.startech.com

NL: Gebruiksaanwijzing - nl.startech.com

PT: Guia do usuário - pt.startech.com

Packaging Contents

- 1 x VGA over Cat5 Remote Receiver
- 1 x Power Adapter
- 1 x Instruction Manual

System Requirements

- UTPE series video transmitter/splitter (i.e. ST124UTPE/ST128UTPE)
- VGA enabled display device (i.e. monitor, projector, etc.)
- Available AC electrical outlet

Installation

Connecting the STUTPRXL Remote Receiver to the transmitter/splitter:

Connect the Cat5 signal source cable running from the UTPE series transmitter/splitter to the RJ45 connector at one end of the Remote Receiver.

Connecting the STUTPRXL Remote Receiver to the VGA display/monitor:

Connect a VGA male/male cable from the display device to the VGA connector on the Remote Receiver.

Powering the Remote Receiver:

Connect the power adapter (provided) to the port marked DC 12V on the Remote Receiver. Connect the opposite end to an AC electrical outlet or other suitable power source. The Power LED will light up.

Adjusting image quality:

Once the necessary connections have been made, power on the VGA display/monitor. On the bottom of the Remote Receiver, are adjustment dials for EQ (sharpness) and GAIN (brightness). Using a small Phillips or slot-head screwdriver, adjust the sharpness with the dial marked EQ in a clockwise direction. Similarly, turn the adjustment dial marked GAIN in a clockwise direction, to adjust the brightness of the displayed image.

Front View



*actual product may vary from photos

Rear View

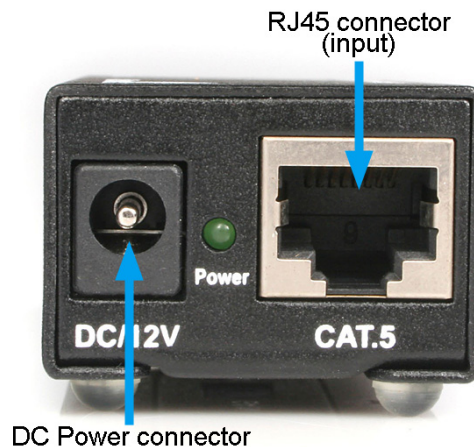

Troubleshooting

The remote display is black, or indicates that there is “no signal”:

Check that the display is receiving power and that all cables are connected securely.

The remote display does not display an image when the local computer wakes up from Standby Mode:

Power the remote display OFF and ON again

The image on the remote display is distorted, or displays a “signal error” or similar error message:

1. Adjust the local computer to a lower resolution and refresh rate until the remote display shows an image.
2. Gradually increase the resolution and refresh rate on the local computer until the remote display ceases to display an image.
3. Return the resolution and refresh rate on the local computer to the highest resolution and refresh rate setting that displayed an image on the remote display
4. Adjust the Signal Equalizer on the Remote Unit for best performance

NOTE: If you are still unable to see an image at the remote location after trying the above solutions, it is recommended that you verify the Ethernet cable installation to the remote display before calling technical support. This can be done using a standard cable tester - if you do not have a cable tester, contact a local computer service or wiring professional.

Specifications

Video Signal	VGA (RGBHV)
External Connectors	1 x DE-15 VGA female 1 x RJ45 Ethernet female 1 x DC Power
LEDs	1 x Power
Compatible Cabling	Cat5/5e
Supported Video Resolutions	1920 x 1200 @ 50m / 150ft 1600 x 1200 @ 100m / 300ft 1280 x 1024 @ 180m / 550ft 1024 x 768 @ 200m / 620ft 800 x 600 @ 300m / 950ft
Enclosure Material	Metal
Power Adapter	12V DC, 600 mA, center positive, type M plug

FCC Compliance Statement

This equipment has been tested and found to comply with the limits for a Class B digital device, pursuant to part 15 of the FCC Rules. These limits are designed to provide reasonable protection against harmful interference in a residential installation. This equipment generates, uses and can radiate radio frequency energy and, if not installed and used in accordance with the instructions, may cause harmful interference to radio communications. However, there is no guarantee that interference will not occur in a particular installation. If this equipment does cause harmful interference to radio or television reception, which can be determined by turning the equipment off and on, the user is encouraged to try to correct the interference by one or more of the following measures:

- Reorient or relocate the receiving antenna.
- Increase the separation between the equipment and receiver.
- Connect the equipment into an outlet on a circuit different from that to which the receiver is connected.
- Consult the dealer or an experienced radio/TV technician for help.

Use of Trademarks, Registered Trademarks, and other Protected Names and Symbols

This manual may make reference to trademarks, registered trademarks, and other protected names and/or symbols of third-party companies not related in any way to StarTech.com. Where they occur these references are for illustrative purposes only and do not represent an endorsement of a product or service by StarTech.com, or an endorsement of the product(s) to which this manual applies by the third-party company in question. Regardless of any direct acknowledgement elsewhere in the body of this document, StarTech.com hereby acknowledges that all trademarks, registered trademarks, service marks, and other protected names and/or symbols contained in this manual and related documents are the property of their respective holders.

Technical Support

StarTech.com's lifetime technical support is an integral part of our commitment to provide industry-leading solutions. If you ever need help with your product, visit www.startech.com/support and access our comprehensive selection of online tools, documentation, and downloads.

For the latest drivers/software, please visit www.startech.com/downloads

Warranty Information

This product is backed by a two year warranty.

In addition, StarTech.com warrants its products against defects in materials and workmanship for the periods noted, following the initial date of purchase. During this period, the products may be returned for repair, or replacement with equivalent products at our discretion. The warranty covers parts and labor costs only. StarTech.com does not warrant its products from defects or damages arising from misuse, abuse, alteration, or normal wear and tear.

Limitation of Liability

In no event shall the liability of StarTech.com Ltd. and StarTech.com USA LLP (or their officers, directors, employees or agents) for any damages (whether direct or indirect, special, punitive, incidental, consequential, or otherwise), loss of profits, loss of business, or any pecuniary loss, arising out of or related to the use of the product exceed the actual price paid for the product. Some states do not allow the exclusion or limitation of incidental or consequential damages. If such laws apply, the limitations or exclusions contained in this statement may not apply to you.